

HOLDING TANK



800.328.3332
satelliteindustries.com

“Increase your business volume with a 300 gallon holding tank system.”

Increase your rental business with specially built holding tanks from Satellite. In addition to adding immediate profits to your business, these strong, impact-resistant polyethylene tanks will provide many years of dependable service. With two internal pillars and thickened corners, Satellite's holding tanks are designed to stack higher, resist cracking and decrease wear-through from sliding and dragging.

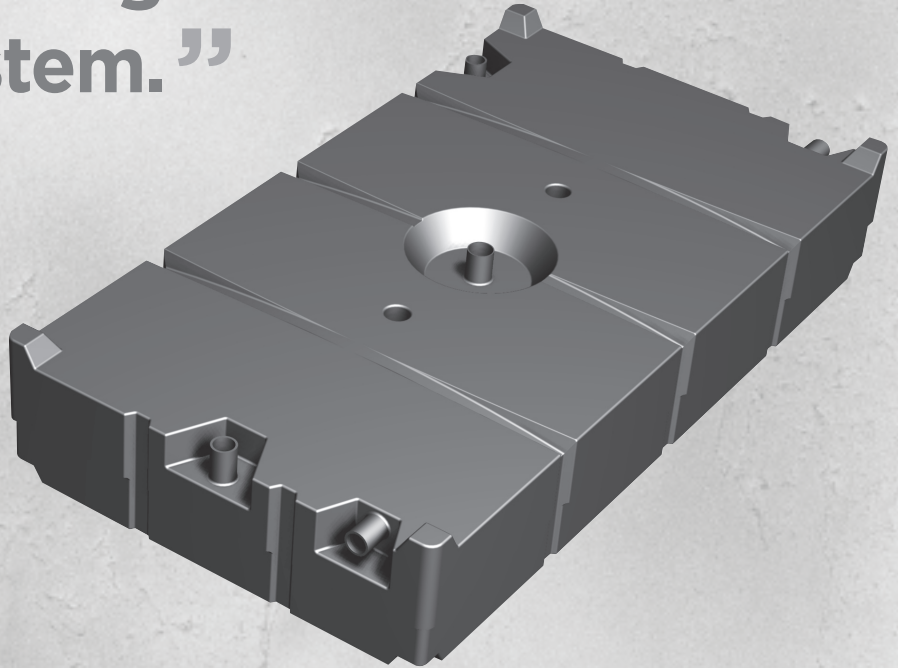

Fittings are molded, not spin-welded, for greater strength and all ports and connectors are recessed to guard against breakage. Also, tanks can be connected end-to-end with standard rubber fittings to increase waste storage when needed.

Don't keep your business on hold; contact your area manager or Satellite whenever you need tanks, deodorizers, hand-wash stations, toilets, trucks or technical assistance.

specs

Capacity: 300 gal. (1135L)

Height: 17.25" (438mm)

Width: 53" (1346mm)

Length: 96" (2435mm)

Weight: 130 lbs. (59 kg.)

Material: Polyethylene

Ports: 6 total

Specifications subject to change without notice.

800.328.3332 | satelliteindustries.com

features

- *Interlocking stacking posts/pockets on all 4 corners*
- *Recessed ports and connections*
- *Two internal pillars for added strength*
- *Optional 5" (127mm) and 10" (254mm) manways*
- *Molded fittings*
- *Thickened corners*
- *End-to-end fittings for linking tanks*
- *Available in gray or natural translucent color*